



CASINGS AND ACCESSORIES

TABLE OF CONTENTS



ABOUT US

Introducing Pile Critter	5
--------------------------------	---

PRODUCTS

Casing joint.....	9
Double wall segmental casing.....	10
Single wall segmental casing.....	11
Casing shoes.....	11
Casing drive adapter.....	12
Casing accessories.....	12

CONTACTS

Team contact info.....	14
------------------------	----

COMPANY

Founded in 2022, PileCrittter is a swiftly growing company in the European drilling market. Our team, though small, is rich in diversity and expertise, encompassing a range of roles from strategic leadership to market-specific business development. Fluent in multiple languages, our team is well-equipped to cater to various European markets. Together, our mission is rooted in delivering value through reliable, high-performance tools essential for construction and civil engineering.

At PileCrittter, we're driven by a relentless dedication to our customers, aiming to be the cornerstone of Europe's drilling industry. Our vision encompasses not just supplying tools but fostering growth and progress in every project we touch. We're focused on enhancing our services by developing rapid response teams, further decreasing dispatch times, and expanding our product catalogue. Join us in redefining drilling industry standards with solutions that speak of quality, efficiency, and innovation!

EU HUB

Focusing on local stock within Europe, PileCrittter has significantly reduced delivery times and improved service dependability for our European clients. This strategic move underscores our dedication to addressing the unique requirements of the European market and strengthening our position in the region.

BESPOKE SERVICE

We are eager to take on special requests, ensuring clients receive precisely what they need for their projects. We specialize in understanding unique requirements and leveraging an extensive product range to fulfill even the most specific demands. With a focus on customization and adaptability, our team is committed to turning special requests into reality, offering solutions that are not just satisfactory, but perfectly aligned with each client's unique business needs.



CASINGS

PileCriter offers a selection of casings and accessories for bored piling construction, featuring international standard steel, advanced welding technology, and innovative structural design. Our products are rigorously tested for quality and strength, ensuring reliable performance and longevity in demanding construction environments.

CASING FEATURES



HIGH QUALITY STEEL MATERIAL

Casing tube material S275, casing joint material 25CrMo.

EXPERIENCED WELDING TECHNOLOGY

Casing tube, casing joint and casing. drive adaptor take submerged arc welding to guarantee stable welding quality and uniform welding performance.

STRICT HEAT TREATMENT FOR CASING JOINT

Casing joint takes two heat treatments to have better toughness and strength. Torsion resistance of casing joint can reach 1000kNm on rotary drilling rig, and 2000kNm on casing rotator.

REASONABLE STRUCTURE DESIGN

The inner side of the double-wall casings adopt the method of welding spiral ribs to make the casings have longer working life and less resistance while pressing down.



CASING JOINT

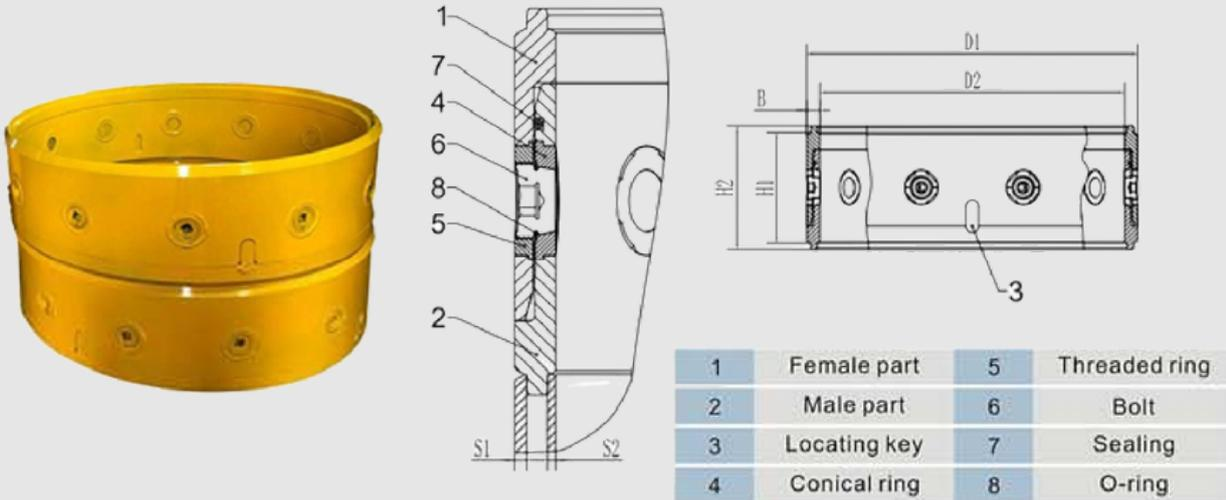

DIMENSIONS							BOLTS AND INSERTS				KEYS		O-RING
D1/D2	H1	H1	S1	S2	B	WEIGHT	BOLT		THREAD RING	CONICAL RING		3	
mm	mm	mm	mm	mm	mm	kg	qty	type	qty	qty	qty	mm	mm
620/540	338	378	12	8	40	179	8	I	8	8	4	40	10x535
750/670	338	378	12	8	40	218	10	I	10	10	4	40	10x665
880/800	338	378	12	8	40	261	10	I	10	10	4	40	10x790
1000/920	338	378	12	8	40	300	10	I	10	10	4	40	10x910
1180/1100	338	378	16	8	40	355	12	I	12	12	4	40	10x1090
1200/1120	338	378	16	8	40	375	12	I	12	12	4	40	10x1110
1300/1220	338	378	16	8	40	393	12	I	12	12	4	40	10x1210
1500/1400	490	530	20	10	50	827	12	II	12	12	4	60	10x1400
1800/1700	490	530	20	10	50	998	12	II	12	12	4	60	10x1695
2000/1880	561	601	20	16	60	1520	12	III	12	12	8	60	10x1870
2200/2080	561	601	20	16	60	1670	12	III	12	12	8	60	10x2070
2500/2380	561	601	20	16	60	1800	16	III	16	16	8	60	10x2360

*This catalog showcases sample products; we offer a wide range of customizable solutions designed to meet your specific business needs.

DOUBLE WALL SEGMENTAL CASING

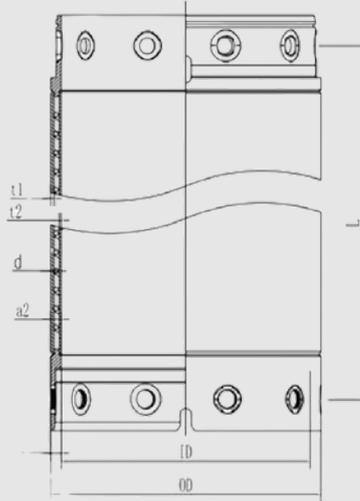

DIAMETER	LENGTH						CASING-WALL THICKNESS-1	CASING-WALL THICKNESS-2	TOTAL THICKNESS	BOLT QTY
	1m	2m	3m	4m	5m	6m				
(mm)	weight (kg)						(mm)	(mm)	(mm)	(nos)
620/540	403	739	1074	1411	1747	2081	12	8	40	8
750/670	492	902	1311	1722	2131	2540	12	8	40	10
880/800	585	1069	1552	2036	2520	3005	12	8	40	10
1000/920	669	1221	1773	2328	2877	3429	12	8	40	10
1180/1100	844	1580	2316	3052	3787	4522	16	8	40	12
1200/1120	872	1620	2370	3120	3870	4620	16	8	40	12
1300/1220	933	1246	2558	3372	4184	4996	16	8	40	12
1500/1400	1433	2628	3817	5009	6210	7393	20	10	50	12
1800/1700	1730	3166	4602	6038	7474	8910	20	10	50	12
2000/1880	2450	4280	6110	7940	9770	11600	20	15	60	12
2200/2080	2700	4720	6740	8760	10780	12800	20	15	60	12
2500/2380	2960	5240	7520	9800	12080	14360	20	15	60	16

*This catalog showcases sample products; we offer a wide range of customizable solutions designed to meet your specific business needs.

SINGLE WALL SEGMENTAL CASING

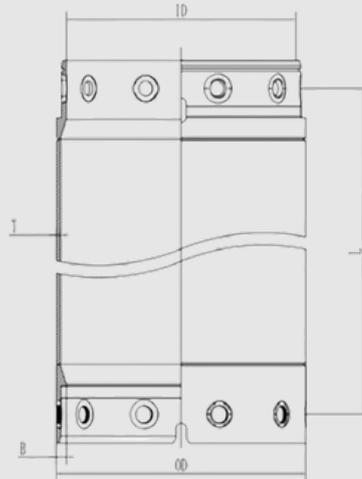

DIAMETER	LENGTH						WALL THICKNESS	WALL THICKNESS	BOLT
D1/D2	1m	2m	3m	4m	5m	6m	T	B	BOLT
(mm)	WEIGHT (kg)						(mm)	(mm)	(Nos)
1300/1220	845	1475	2105	2735	3365	3995	20	40	12
1500/1400	1310	2220	3130	4040	4950	5860	25	50	12
1800/1700	1580	2675	3770	4865	5960	7055	25	50	12
2000/1880	2140	3355	4570	5785	7000	8215	25	60	12
2200/2080	2350	3690	5030	6370	7710	9050	25	60	12
2500/2380	2575	4100	5625	7150	8675	10200	25	60	16

CASING SHOES

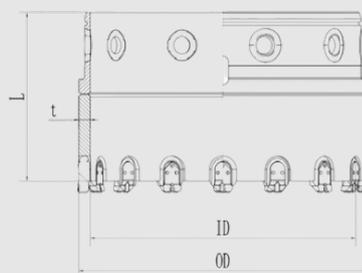

DIAMETER (mm)	620	750	880	1000	1180	1300	1500
DRILLBIT QUANTITY	14	16	18	18	20	24	30
WEIGHT (kg)	309	374	439	500	589	653	955

*This catalog showcases sample products; we offer a wide range of customizable solutions designed to meet your specific business needs.

CASING DRIVE ADAPTER

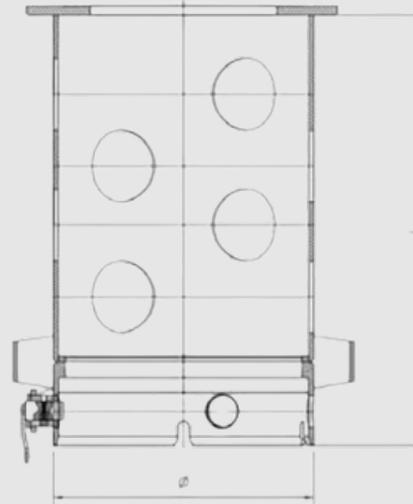

Casing drive adapter's upper connection can be customised according to the size of the model specified by the customer.

CASING ACCESSORIES



MODEL: PC-WS39

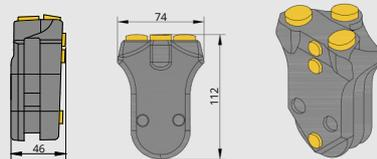

MODEL: PC-WS46

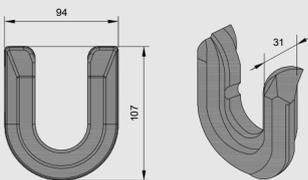

MODEL: PC-WSH39-52



**This catalog showcases sample products; we offer a wide range of customizable solutions designed to meet your specific business needs.*

CASINGS



EXAMPLES



CASING DIA. (MM)	OD1000/ID920
TYPE	Double-walled casing
DRILLING DEPTH	84m
RIG MODEL	Liebherr LB36



CASING DIA. (MM)	OD620/ID540, OD1000/ID920
TYPE	Double-walled casing
DRILLING DEPTH	50m
RIG MODEL	Soilmec SR80



CASING DIA. (MM)	OD620/IF540, OD750/ID670, OD880/ID800
TYPE	Double-walled casing
DRILLING DEPTH	50m
RIG MODEL	Casagrande B200



CASING DIA. (MM)	OD1180/ID1100, OD1280/ID1200
TYPE	Double-walled casing
RIG MODEL	XCMG XR400S drilling rig

**This catalog showcases sample products; we offer a wide range of customizable solutions designed to meet your specific business needs.*



Connect with us for a personalised service.

Reach out to be assigned your dedicated account manager, ready to assist with all your project needs:

Tel: +371 200 20 375

E-mail: info@pilecritter.com

www.pilecritter.com

